

Ratio Electric Solar Box

MANUAL



Ratio
ELECTRIC

Thank you for choosing Ratio Electric Solar Box

Manufacturer

Ratio Electric B.V.

Ambachtsstraat 12
NL - 3861 RH Nijkerk
The Netherlands
Tel. +31-33-2452360
info@ratio.nl
www.ratio-electric.com

UK English - Original
EV081 - V00-08 - 01/2022

Preface

About this document

This manual contains technical descriptions and instructions for the following product:

Category of product	Charger for Electric Vehicles
Product name	EV Solar Box 32A
Art. No.	378xx
Hardware version*	Charger4-kWh-HB-1.2
Serial number	

* This is marked on the PCB of the charger.

Write down the serial number of your product in the table above for future reference.

This manual contains all instructions and safety information for installation, commissioning, use and maintenance of the product.

This manual is intended for:

- the qualified technician who installs the product;
- the end-user who uses the charger;
- the product owner who maintains the product.

Original instructions

This manual has been translated into multiple languages. The original manual is written in UK English. All other language versions are translations of the original manual.

Copyright

The content of this manual is protected by copyright and other intellectual property laws. The content of this manual may only be copied, modified, reproduced, translated with express written permission from the manufacturer. This manual may only be published, transmitted, displayed or made available to a third party with express written permission from the manufacturer.

Disclaimer of liability

Ratio Electric B.V. cannot be held responsible for personal injury, damage to the product or property damage caused by incorrect use, foreseeable misuse or failure to follow the instructions in this manual. This also applies to unauthorized modifications of the product and the use of non-approved spare parts, tools or accessories.

Ratio Electric B.V. reserves the right to modify this manual without notification beforehand.

Table of contents

1. Safety	5	6. Commissioning	34
1.1. Symbols and labels	5	6.1. Initial configuration of the charger	34
1.2. Intended use	6	6.2. Testing	36
1.3. Reasonably foreseeable misuse	6	7. Use	37
1.4. Qualification of personnel	6	7.1. Display overview	37
1.5. Personal protective equipment (PPE)	7	7.2. Start charging	38
1.6. Safety precautions	7	7.3. During charging	40
2. Description of the product	8	7.4. Stop charging	40
2.1. Charger components	10	8. Settings	41
2.2. Sensorbox components	10	9. Troubleshooting	42
3. Technical data	11	10. Maintenance	43
3.1. Nameplate/Marking	12	11. Service	44
4. Transport and storage	12	12. Warranty	44
4.1. Transport	12	13. Disposal	45
4.2. Storage	12	Appendix 1. FCC compliance	46
5. Installation	13	Appendix 2. EC Declaration of conformity	47
5.1. Preparation	13		
5.2. Install the power cable in the consumer unit	14		
5.3. Install the sensorbox in the consumer unit	15		
5.4. Mount the charger to a wall	18		
5.5. Connect the power cable to the charger	20		
5.6. Install the data cable in the charger	24		
5.7. Install a data cable between two chargers for power sharing	27		
5.8. Checks before finishing the installation	31		
5.9. Finish the installation	32		

1. Safety

Please make sure you have fully read and understood the instructions in this manual before you start installing or using the product. If you fail to follow the instructions from this manual you can put persons, surroundings, the environment and the product at risk. Store this manual in an accessible place near the product for future reference.



Always comply with the information, such as labels and the nameplate, attached directly to the product and keep the information in a legible condition.

Always comply with any applicable laws and regulations that have not been accounted for in this manual.

1.1. Symbols and labels

1.1.1. Safety warnings

This manual contains safety warnings that may result in injury when ignored. Each safety warning is indicated with a signal word. The signal word corresponds with the level of risk of the described hazardous situation, see the table below.

Signal word	Risk of injury	Result when instruction is ignored or not followed correctly
 WARNING	Medium	Could result in death or serious injury
 CAUTION	Low	Could result in minor or moderate injury

Safety warnings at the start of a section, apply to the entire section.

Safety warnings that refer to a particular sentence or procedure step are embedded in the running text.

1.1.2. Notices

Messages that are not hazard-related are indicated with the signal word NOTICE. These messages do not have a safety alert symbol.

Signal word	Meaning
NOTICE	Could result in damage to the product when instruction is ignored or not followed correctly
Note	Additional information or emphasis on an instruction

1.2. Intended use

The Ratio Electric Solar Box is a private charger intended to charge electrical vehicles using power from solar panels and household power grid. The product can be operated indoors and outdoors.

The product must only be operated within its performance limits and under the permitted ambient conditions, as stated in the technical specifications in chapter 3.

The product can be mounted flush to a wall, or to a separately available pole for pavement or soil.

Safe use of the product is only guaranteed if it is used as intended.

1.3. Reasonably foreseeable misuse

The following is considered foreseeable misuse:

- Use in an environment that varies from or exceeds the given environmental conditions.
- Use that varies from or exceeds the given operating conditions.
- Failure to comply with the instructions in this manual.
- Failure to eliminate faults, malfunctions or defects of the product that impose safety risks.
- Failure to carry out the inspections and maintenance operations as described in this manual.
- Unauthorized removal or modification of parts or safety devices of the product.
- Use of spare parts or accessories that have not been approved by the manufacturer.
- Operation in a flammable and/or explosive environment.
- Operation in closed-off or poorly ventilated rooms.

1.4. Qualification of personnel

Only authorized technicians are allowed to perform installation and maintenance of the product. They must possess the following qualifications:

- are legal of age;
- are familiar and abide by the safety instructions and sections of this manual related to installation and maintenance of the product;
- are familiar with and abide by the applicable local, national and international laws and regulations;
- are able to recognize the possible dangers of the product and take the necessary measures to protect persons and property;
- have received adequate training in the safe installation and maintenance of this product;
- have obtained authorization to access the product.

1.5. Personal protective equipment

Wear the appropriate personal protective equipment (PPE) according to the manual of any tools you use during installation of the charger.

Wear insulating gloves when installing wires and touching electrical components to avoid damaging the product by static discharge.

1.6. Safety precautions

Despite the safe design and construction of the product and the prescribed protective measures, the product possesses residual risks. This manual provides safety messages to indicate these risks. The formatting and appearance of safety messages that are dedicated to a particular section or sentence is explained in chapter 1.1.

Read all the safety warnings and instructions before using the product. Failure to follow the warnings and the instructions may result in electric shock, fire and/or serious injury.

WARNING

- This device should be supervised when used around children.
- Do not put fingers into the electric vehicle connector.
- Do not use this product if the flexible power cord or EV cable are frayed, have broken insulation, or any other signs of damage.
- Do not use this product if the enclosure or EV connector are broken, cracked, open, or show any other indication of damage.
- Switch off the MCB in your electrical cabinet and immediately contact Customer Support for service if at any time you think the equipment is unsafe,. Do not use your Solar Box until the problem is identified and corrected.
- Improper connection of equipment-grounding conductor can result in a risk of electric shock. Check with a qualified electrician or serviceman if you doubt whether the product is properly grounded.
- Do not use this product if it does not function according to the instructions in this manual. Seek advice from Ratio Electric, your vendor, or a qualified electrician or serviceman.
- Do not remove the charging plug while a charging session is active.
- Children should not be allowed to use this product. Do not allow children to play in or around the product.

⚠ CAUTION

- Make certain the supply cable of the product is positioned so it will not be stepped on, tipped over, or otherwise subjected to damage or stress.
- There are no user serviceable parts inside. Refer to the Customer Support section in this manual for service information. Do not attempt to repair or service the product yourself.
- Do not operate this product if it or the supply cable or housing is visibly damaged. Switch off the MCB in the electrical cabinet and contact your Service Representative for service immediately. Refer to the Customer Support section in the manual for information on the Service Representative in your area.
- Only use this product to charge electric vehicles equipped with a conductive charge port. See the vehicle's owner's handbook to determine if the vehicle is equipped with a conductive charge port.
- Use of any adaptors is not allowed with this product.
- Only use certified type 1 or type 2 charging cables with this product.

NOTICE

- Do not drop the product and avoid bumping.
- Do not store the product in an environment that exceeds the ambient conditions as stated in this manual.
- Do not expose the internal components product to moisture.
- Do not immerse the product in water or any other liquid.

2. Description of the product

The EV Solar Box is a Mode 3 charger for charging electrical vehicles (EV) that complies with the IEC61851 standard. The Solar Box is equipped with several features to optimise power consumption and charging performance.

Dynamic Load balancing

The product uses a sensor box with current transformer(s) to measure the live power consumption of the power grid per phase and uses that information to manage the power output to your EV. When more electrical appliances are used, the power output to the EV is reduced to avoid overloading the power grid.

Power sharing

If you have purchased more than one charger, you can interconnect the chargers with a data cable and use the integrated power sharing feature to equally distribute the available power across the chargers points using the data from the sensorbox.

The sensorbox uses up to three CT clamps, one for each phase of the main grid, to measure the current flow of the main grid. The sensorbox is also compatible with solar panel installations and can measure the direction of the current.

One charger is connected to the sensorbox with a data cable. This charger acts as the Main Controller (MAIN), and manages the power for up to three Sub Chargers (SUB1, SUB2 and SUB3).

Note: Pure Solar mode is not compatible with power sharing.

User display

The charger is equipped with a user display for easy access of charging data and for adjusting several settings.

Charge modes

The charger has four available charge modes:

Basic	The charger charges the EV using a set maximum power in Amps (I-Max).
--------------	---

Note: This mode does not have a load balancing feature to prevent the grid connection from being overloaded.

Smart	The charger only charges the EV when the available power is above the minimum set power in Amps (I-Min) and below the maximum power that is still available on the main grid.
--------------	---

Note: This load-balancing feature prevents that the grid connection is being overloaded when multiple electrical users are used at the same time in the house

Smart  (Smart Solar)	The charger only charges the EV when the available power is above the minimum set power in Amps (I-Min smSolar) and below the maximum power that is still available on the main grid.
---	---

If the charger is charging the EV and there is still net power generation, the charger uses this surplus of energy to charge the car in addition to the minimum set power.

Pure  (Pure Solar)	The charger only charges the EV when there is a net power generation (e.g. from solar panels), that is above the minimum set power in Amps (I-Min puSolar).
---	---

Note: Pure Solar mode is not compatible with power sharing. If you set the charge mode to Pure Solar, power sharing will be disabled.

2.1. Charger components

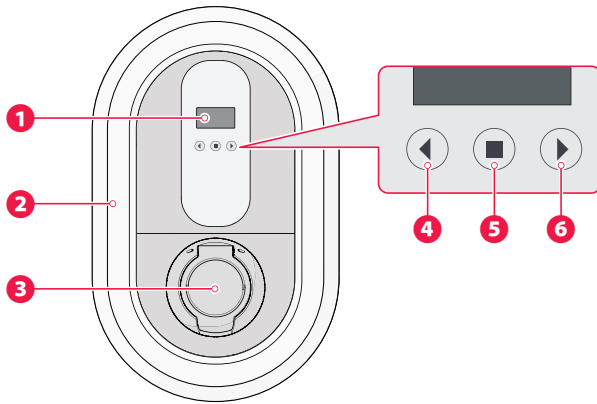

- 1 User display
- 2 Front cover ring
- 3 Charge socket

- 4 Left arrow button
- 5 Enter button
- 6 Right arrow button

2.2. Sensorbox components

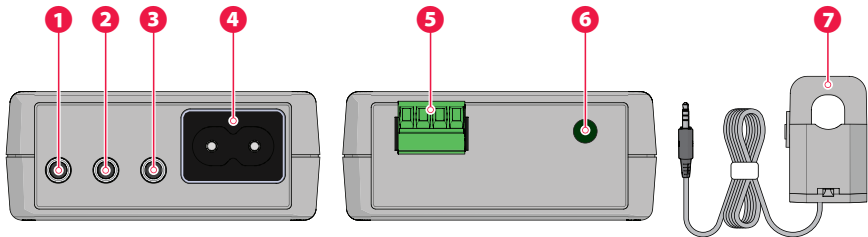

- 1 Phase 1 (L1) CT clamp input
- 2 Phase 2 (L2) CT clamp input
- 3 Phase 3 (L3) CT clamp input
- 4 Mains input*

- 5 Data cable terminal block connector
- 6 Status LED
- 7 CT clamp (3× for 3-phase installation)

*The mains input does not supply power to the sensorbox. It is used to determine the direction of the measured current. The provided mains input cable must be installed on phase 1 (L1) of the main power grid and is orientation sensitive.

3. Technical data

Product name	EV Solar Box 32A
Art. no.	378xx
Charging System	IEC61851, Mode 3
Cable version car connector	IEC 62196, type 1 or type 2
Outlet version	IEC 62196, type 2 Outlet
Power input	single-phase or 3 phase, 230V-400V AC, 16A-32A
Max Power output	3,7 kW, 7,4 kW, 11 kW, 22 kW, 230V-400V AC
Frequency	50 Hz \pm 5%
Protection against electric shock	Class I
Residual current detection	DC 6mA
Dimensions	400 mm \times 250 mm \times 105 mm
Housing	PC/ABS-VO
Weight	4 kg (incl. cable)
IP Protection rating	IP54, rain-tight
Altitude	Up to 2000 m.
Ambient temperature	-25 °C to +40 °C
External magnetic field	Not exceeding five times the earth's magnetic field in any direction.
Sinusoidal wave distortion	Not exceeding 5%
Relative humidity (maximum value at 40 °C)	75%
Markings	CE
Ventilation	Not supported
Required protection device type	Type A
Required protection device rating	30 mA

3.1. Nameplate/Marking

The product is marked in accordance with the applicable legislation requirements. The nameplate/markings is located on the bottom of the housing, above the cable inlets.

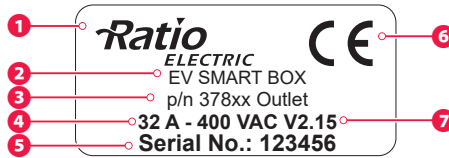

- | | | | |
|---|-------------------|---|---------------------------|
| 1 | Manufacturer | 5 | Product serial number |
| 2 | Product name | 6 | CE marking |
| 3 | Product number | 7 | Firmware/hardware version |
| 4 | Rated input power | | |

4. Transport and storage

4.1. Transport

Transport the product in the original packaging, or suitable replacement packaging that provides adequate protection from vibrations, bumps, moisture, dust, and debris. Be careful not to drop the product and prevent it from moving or bumping into objects while transporting.

Excessive vibrations could loosen wire connections and cause the product to malfunction.

4.2. Storage

Always disconnect the product from the power supply when storing the product.

Store the product in environmental conditions within the limits stated in chapter of 3 this manual.

Store the product in the original packaging or a suitable replacement packaging to protect the product from moisture, dust, and debris.

Do not store anything on top of the product.

5. Installation

5.1. Preparation

⚠ WARNING

- The installation must be done by a qualified and licensed electrician according the local legislation.
- The electrical installation must be free of power during the entire installation period.
- Since this charger uses circuits that reference to ground, no megging must be done after connecting to power.

5.1.1. Check the contents

1. Open the box and remove the contents.
2. Place all parts on an empty surface to avoid losing any parts.
3. Check if all parts are present and undamaged using the overview below. In case of any parts missing or damaged, please contact your local dealer or Ratio Electric B.V.

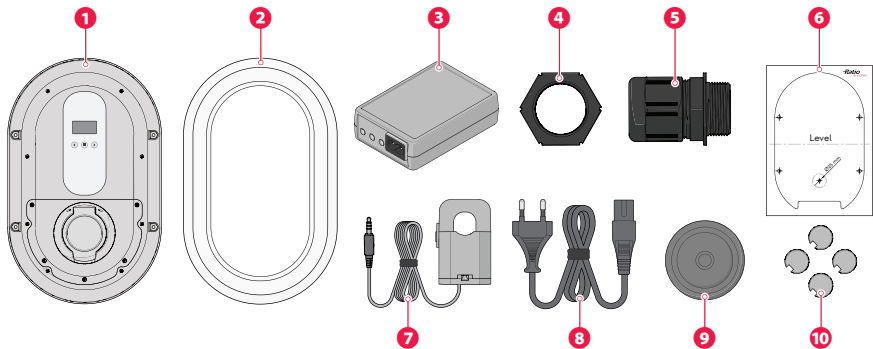

- | | |
|----------------------------|--|
| 1 Charger | 6 Drilling template |
| 2 Front cover ring | 7 Current transformers (3× for 3-phase installation) |
| 3 Sensorbox with connector | 8 Mains input cable for sensorbox |
| 4 Locknut for cable gland | 9 Rubber grommet for data cable |
| 5 M25 cable gland | 10 Screw caps (4×) |

5.1.2. Required tools

- Wood screws 5×35 mm (4×)
- Appropriate wall plugs (4×) (if applicable)
- Spirit level
- Hammer
- Screwdrivers:
 - Size 3 flathead
 - TX10 Torx
 - Voltage tester

5.1.3. Required wiring and electrical protection

	16 A	32 A
Wiring cross section 1-phase*	3 × 6,00 mm ² , solid wire*	
Wiring cross section 3-phase*	5 × 6,00 mm ² , solid wire*	
Mains Circuit Breaker (MCB)	20 A, B/C-characteristic	40 A, B/C-characteristic
Residual Current Device (RCD)	30 mA, Type A	
Data cable	Shielded UTP cable or 4×0,25 mm ² cable*	

* max 25 m cable length

5.2. Install the power cable in the consumer unit

1. Switch off the Main Circuit Breaker (MCB) in the consumer unit to cut power to the main grid.
2. Lay down a power cable and data cable between the consumer unit and the installation location of the charger.
3. Install a dedicated 30 mA, Type A Residual Current Device (RCD), or use an available 30 mA, Type RCD.
4. Strip the wires of the power cable.
5. Connect the power cable wires to the dedicated RCD in the consumer unit.

5.3. Install the sensorbox in the consumer unit

1. Mount the Sensorbox to a free location in the consumer unit.

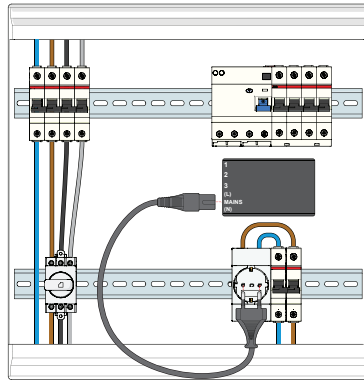

2. Plug the mains input cable into the sensorbox.
3. Plug the other end of the mains input cable into a power outlet.

Note: The mains input is orientation sensitive. If the mains plug is inserted upside down, the measurements of the sensorbox will be inaccurate. Check the markings on the sensorbox for the correct orientation.

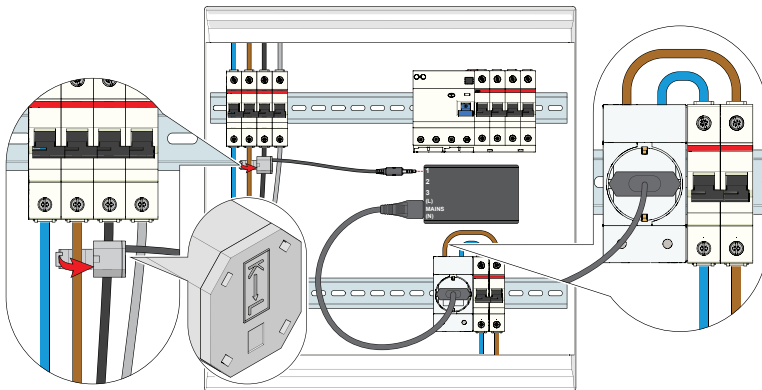

4. Check on which phase of the main power grid the power outlet is connected.
5. Place a current transformer around the same phase wire of the main power grid, between the main fuse and the solar panel connections.
6. Insert the 3,5 mm jack of the current transformer to the L1 input on the Sensorbox.

Note: For correct functioning of the sensorbox, you must install this current transformer around the same phase as the power supply (L).

Note: Make sure the arrow on the current transformer points towards the entry point of the main power grid. See the image below for more information on the correct mounting location of the CT clamps.

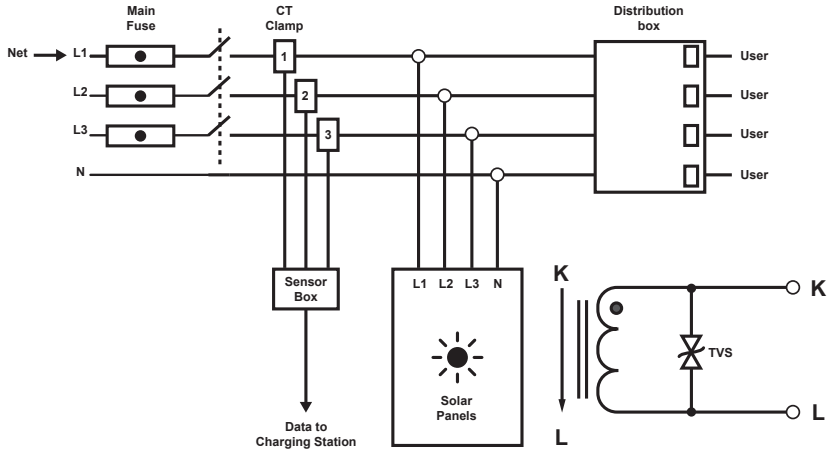

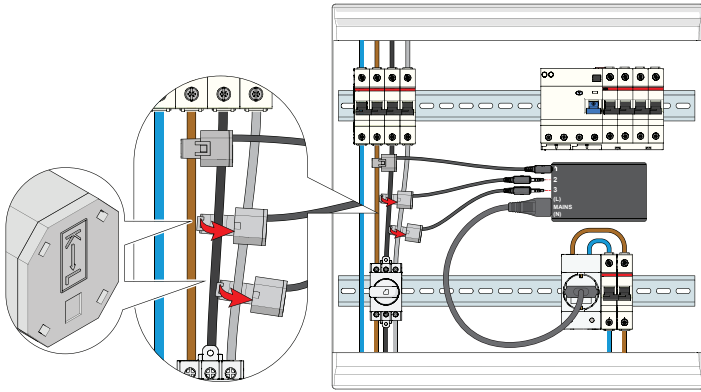

- Place the remaining current transformers around the other phase wires of the main power grid, also between the main fuse and the solar panel connections.

Note: Make sure the arrows on the current transformers point towards the entry point of the main power grid.

Note: It is crucial for the functioning of the charger that you insert the current transformers into the correct input.

- Insert the 3,5 mm jacks of the current transformers to the L2 and L3 input on the Sensorbox.

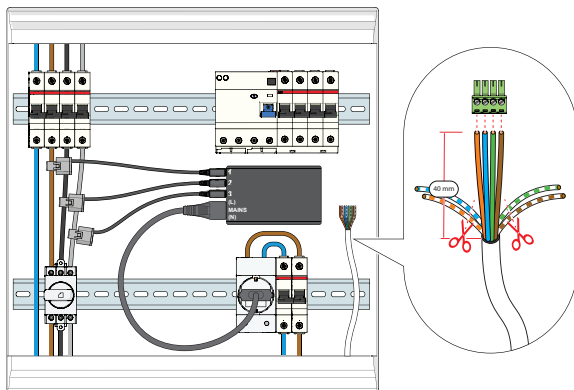

- Strip the wires of the data cable (not included).
- Insert four wires of the data cable into the green terminal block connector.
- Secure the wires to the terminals. Use a screwdriver.
- Write down the colours and order of the inserted wires of the data cable.

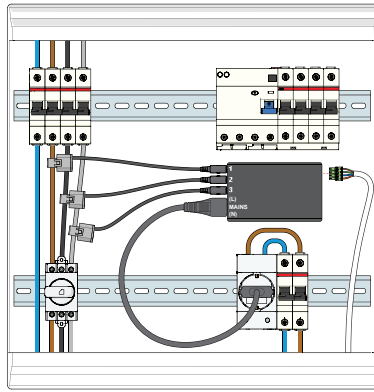

13. Insert the terminal block connector into the sensorbox.

5.4. Mount the charger to a wall

Note: In case you have purchased the optional pole for the charger, check the installation manual provided with the pole for mounting instructions.

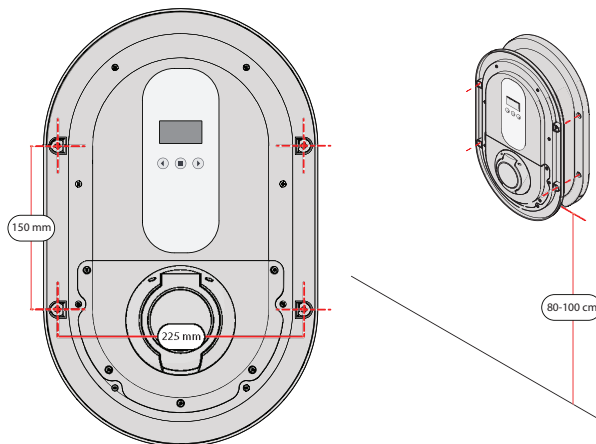

1. Tape the provided drilling template to the wall at the installation location, with the bottom of the template about 80-100 cm above the ground.
2. Ensure the template is level. Use a spirit level.

Alternatively

1. Hold the charger against the wall at the installation location, with the bottom of the charger about 80-100 cm above the ground.
2. Ensure the charger is level. Use a spirit level.
3. Mark the locations of the holes in the charger housing on the wall.
4. Carefully remove the charger and lay it on a flat, stable and dry surface.

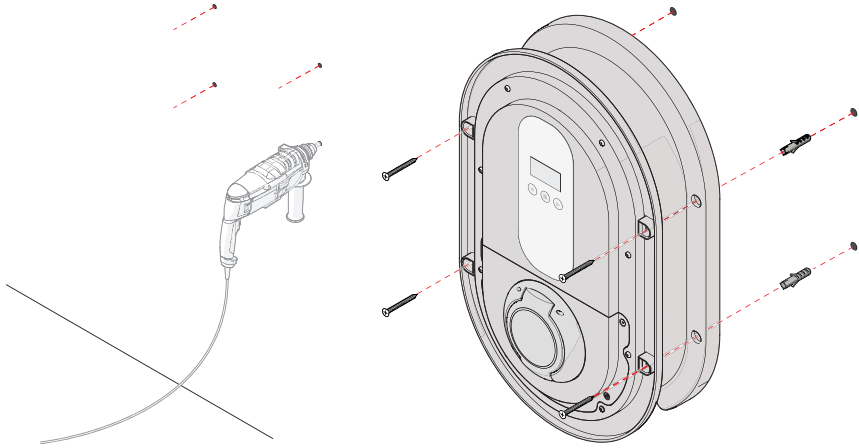

5. Drill the holes in the wall. Use an appropriate drill and drill bit.
6. Insert wall plugs, if applicable.
7. Align the charger with the holes in the wall and secure it with four 5×35 mm wood screws (not included).

5.5. Connect the power cable to the charger

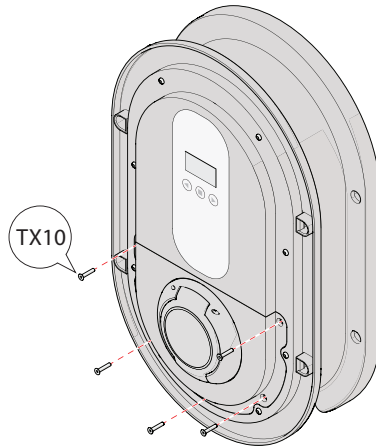

1. Remove the five Torx screws from the housing lid. Use a size TX10 screwdriver.
 2. Move the housing lid to the side to access the inner circuitry of the product.
-

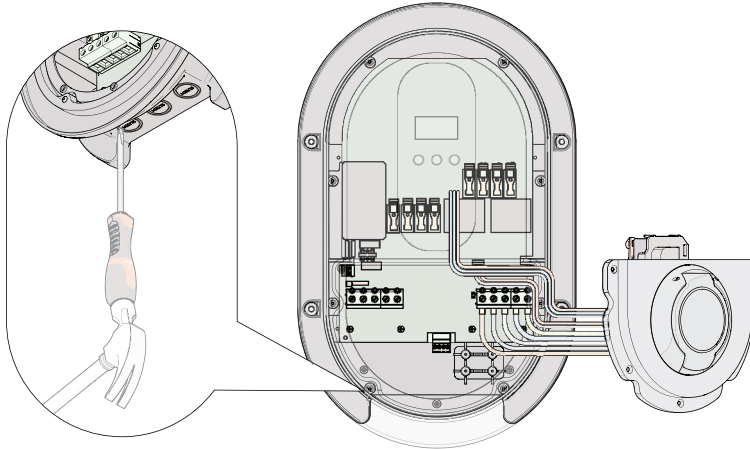

3. Carefully remove the left cable inlet cover. Use a flathead screwdriver and hammer.

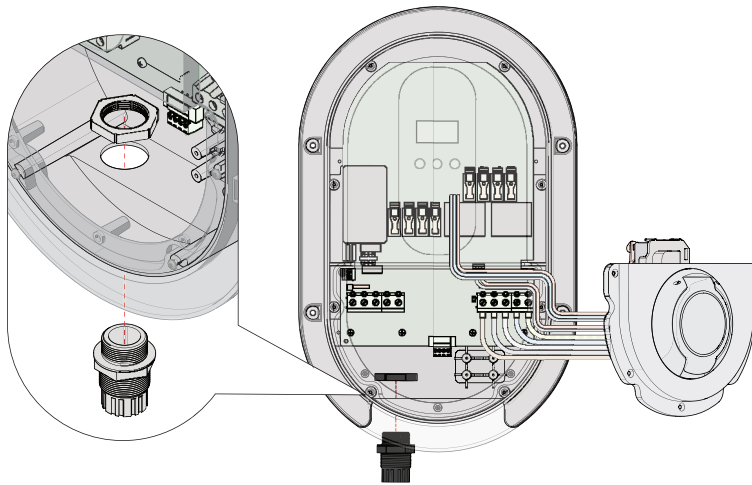

4. Remove the sealing nut from the cable gland.
5. Insert the cable gland through the left cable inlet.
6. Secure the cable gland with the locknut.

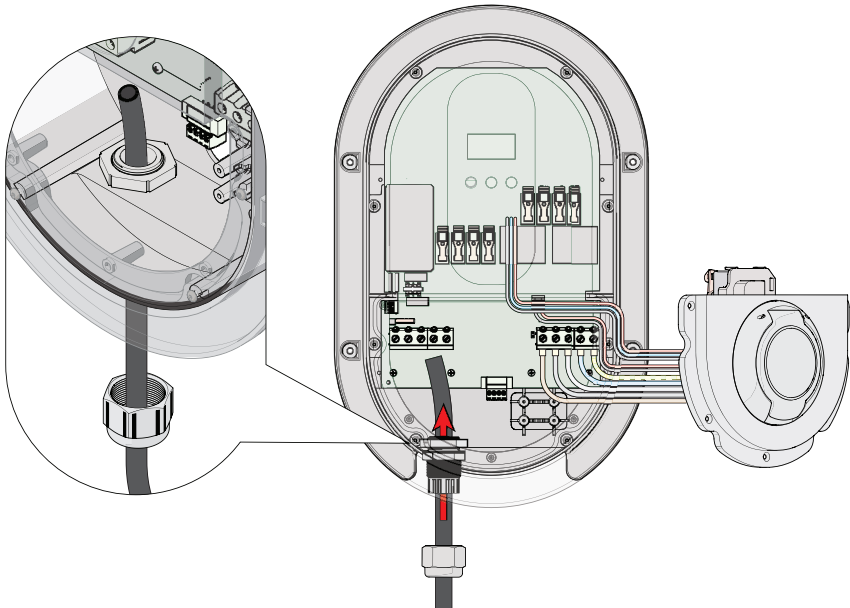

7. Guide the power cable through the sealing nut.
8. Guide the power cable through the cable gland.

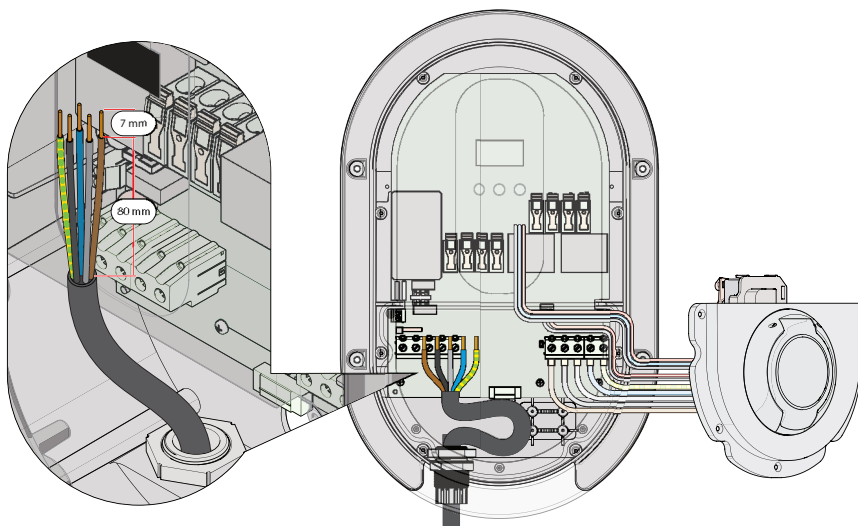

9. Strip the wires of the power cable.

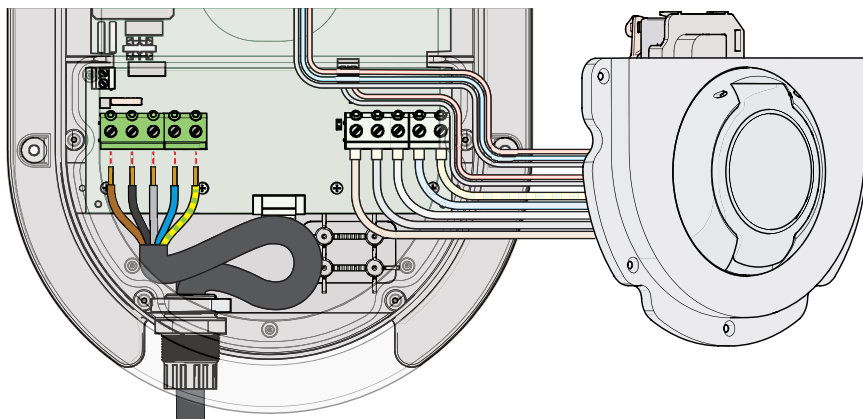

10. Connect the stripped wires to the correct terminals of the left terminal block.

L1 = Brown

L2 = Gray*

L3 = Black*

N = Blue

Earth = Green/Yellow

* for 3 phase installation only.

11. Secure the wires to the terminals using a voltage tester screwdriver.

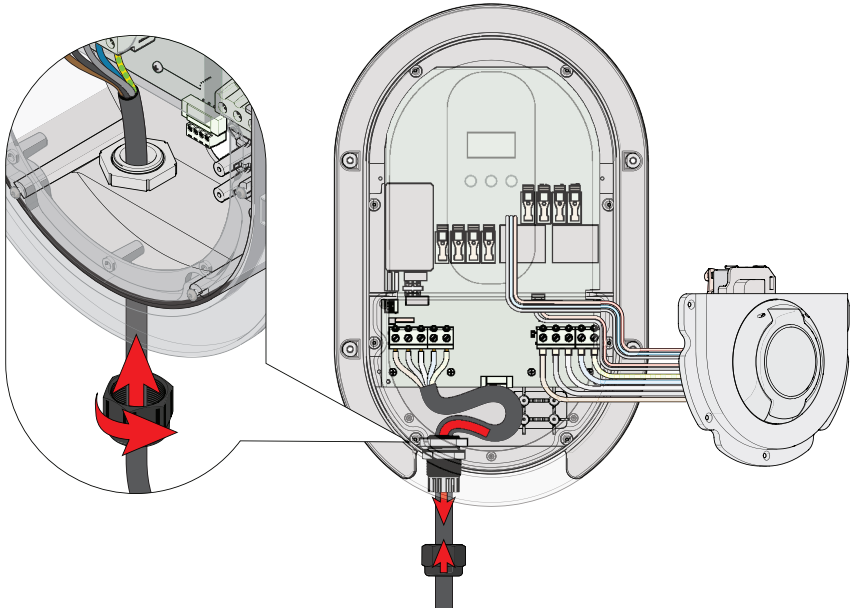

12. Gently pull the excess power cable out of the charger.

13. Secure the power cable in place by tightening the sealing nut onto the cable gland.

5.6. Install the data cable in the charger

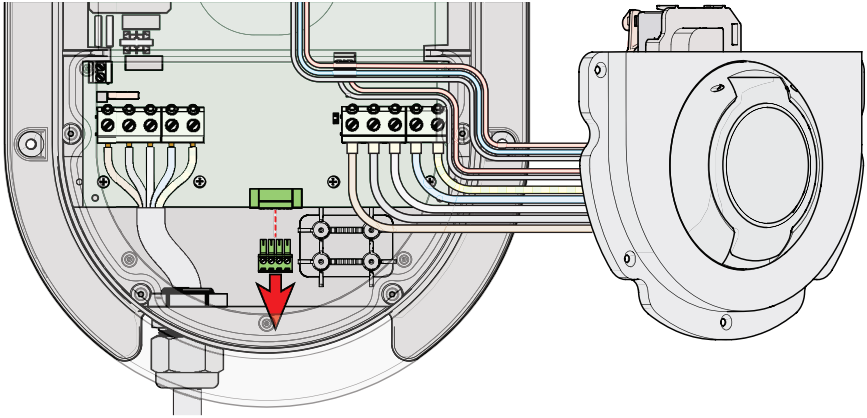

1. Remove the terminal block connector from the charger

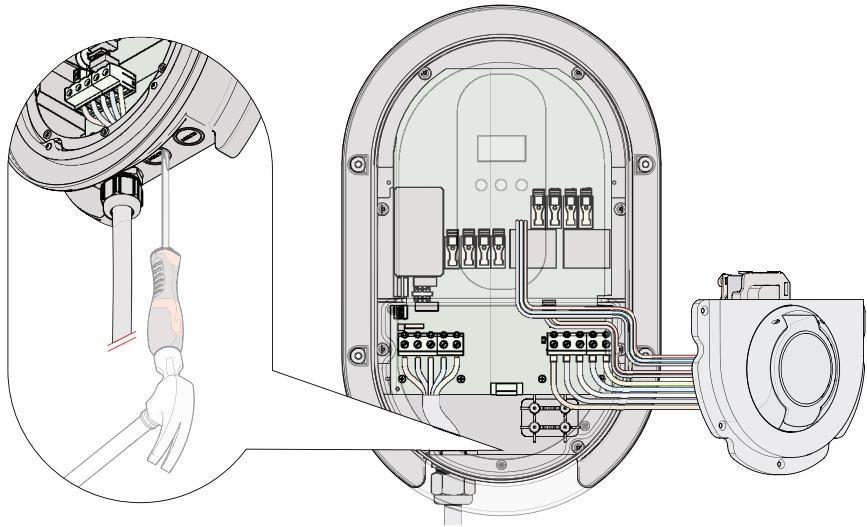

2. Carefully remove the centre cable inlet cover. Use a flathead screwdriver and hammer.

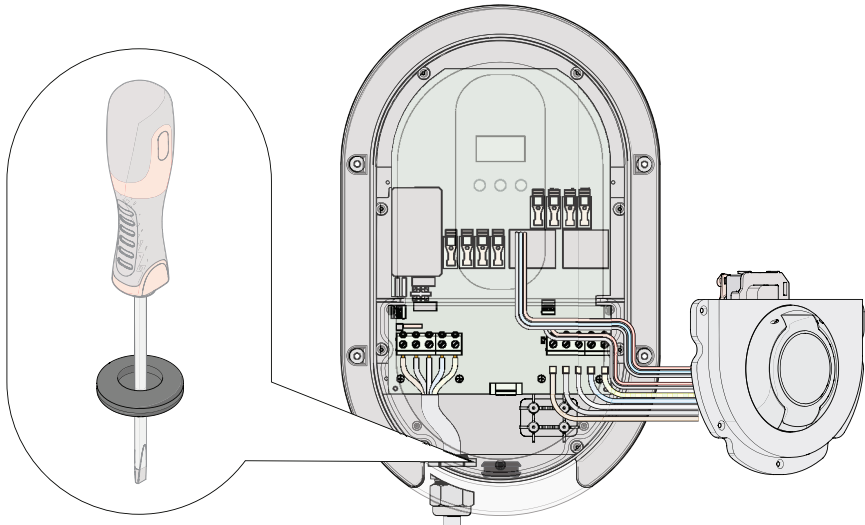

3. Punch a hole in the centre of the rubber cable grommet using a screwdriver.
4. Insert the rubber cable grommet into the centre cable inlet.
5. Guide the data cable through the rubber grommet.

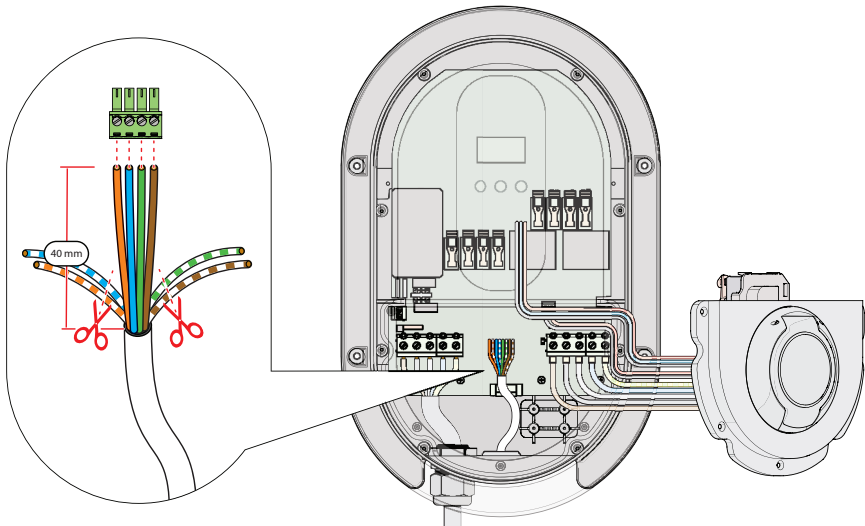

6. Strip the wires of the data cable.
7. Take the four solid coloured wires.
8. Remove the unused wires.

9. Insert the wires into the terminal block connector in the exact same order as in the sensorbox.
10. Secure the wires to the terminals. Use a voltage tester screwdriver.

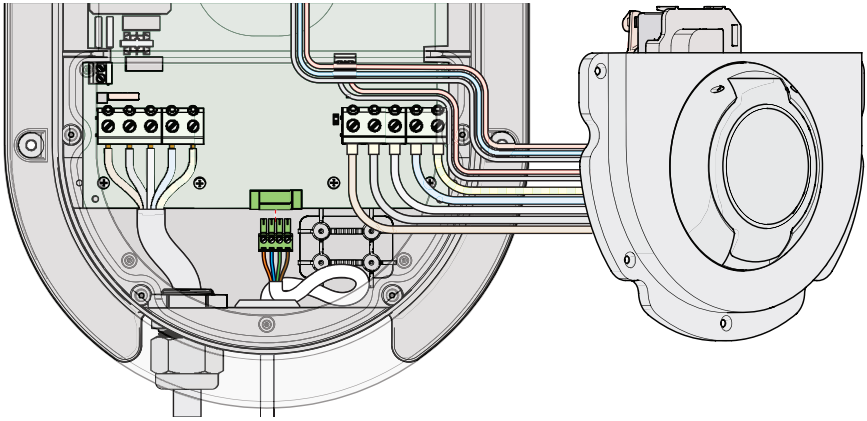

11. Insert the terminal block connector into the charger.

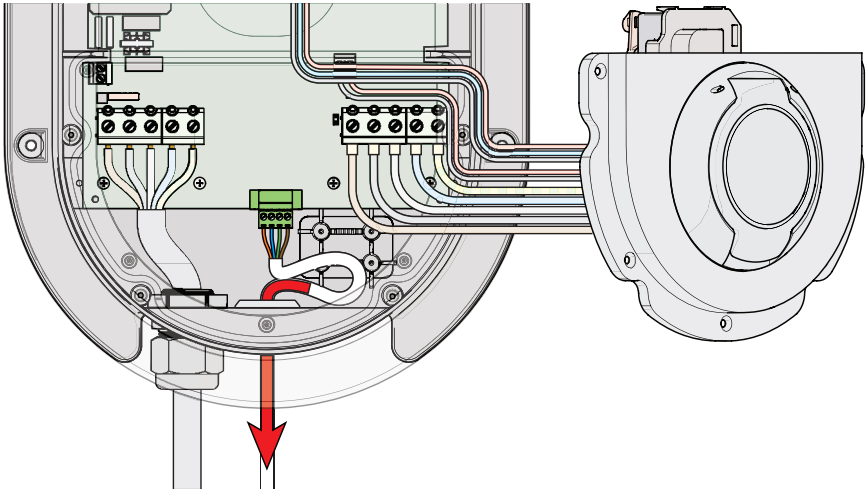

12. Gently pull the excess ethernet cable out of the charger.

If you have purchased a single charger, please continue to chapter 5.8.

If you have purchased multiple chargers and want to use the Power sharing feature, please continue to chapter 5.7.

5.7. Install a data cable between two chargers for power sharing

5.7.1. In the Main Controller

1. Lay down a data cable between the Main Controller and first Sub charger.
2. Remove the terminal connector of the existing data cable from the charger.
3. Guide the second data cable alongside the existing data cable through the rubber grommet.

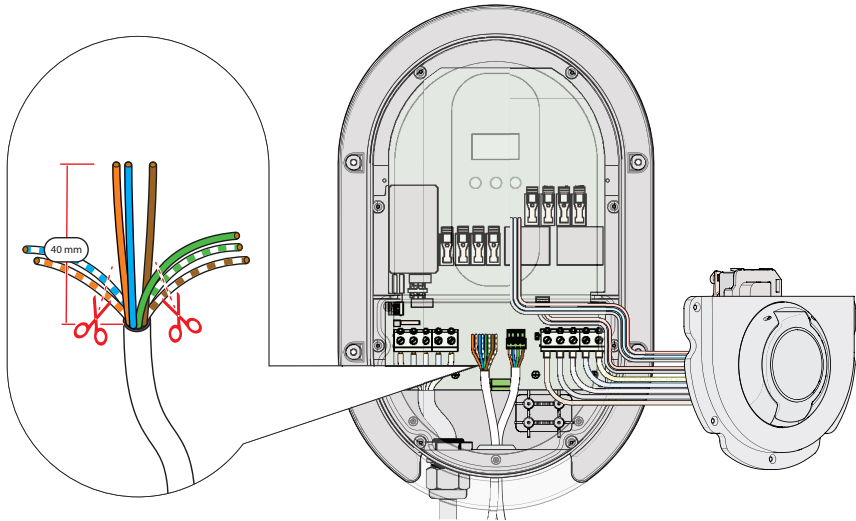

4. Strip the wires of the data cable.
5. Match the coloured wires to the wires that are already connected to A, B and GND of the terminal block connector.

Note: Do not connect the +12V wire to terminal 3 of the connector.

6. Remove the unused wires.

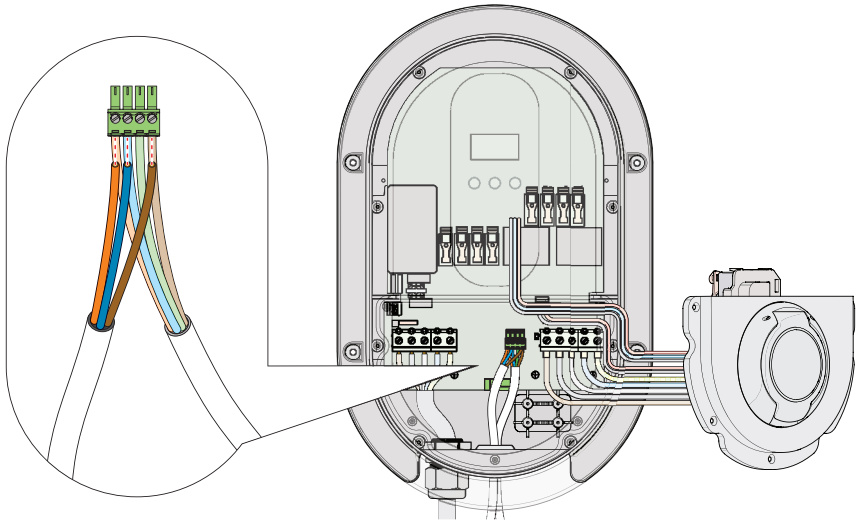

7. Insert the wires into the terminal block connector alongside the existing wires.
8. Secure the wires to the terminals using screwdriver.

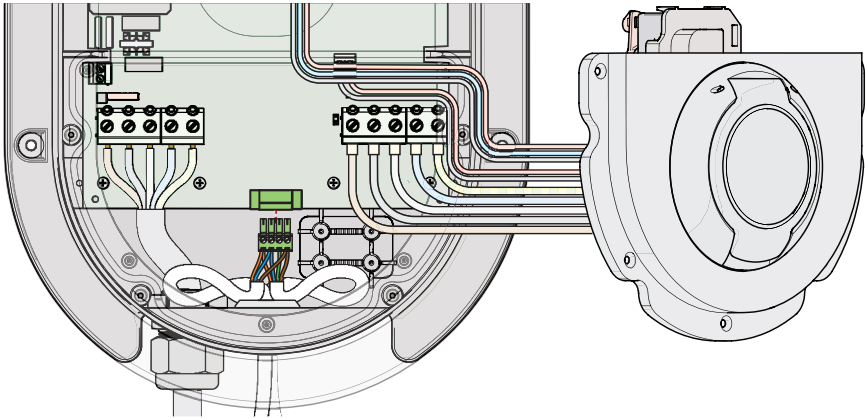

9. Insert the terminal block connector back into the charger.

5.7.2. In the Sub charger

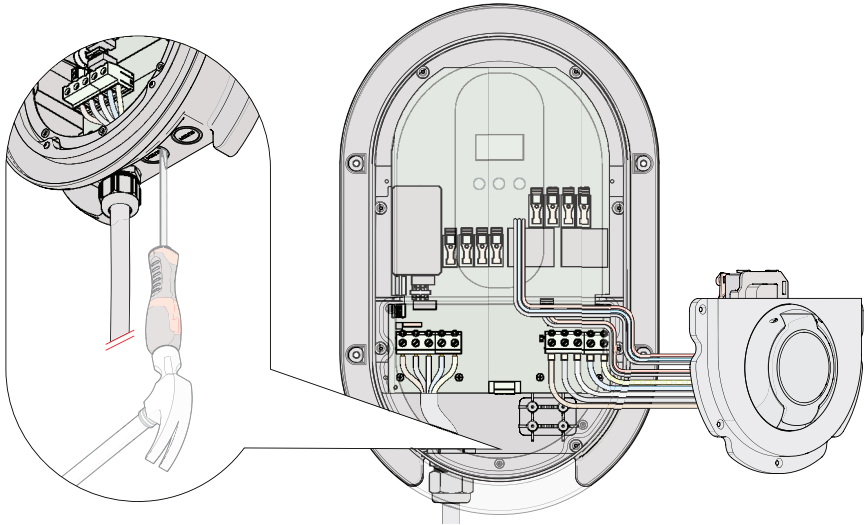

1. Carefully remove the centre cable inlet cover. Use a flathead screwdriver and hammer.

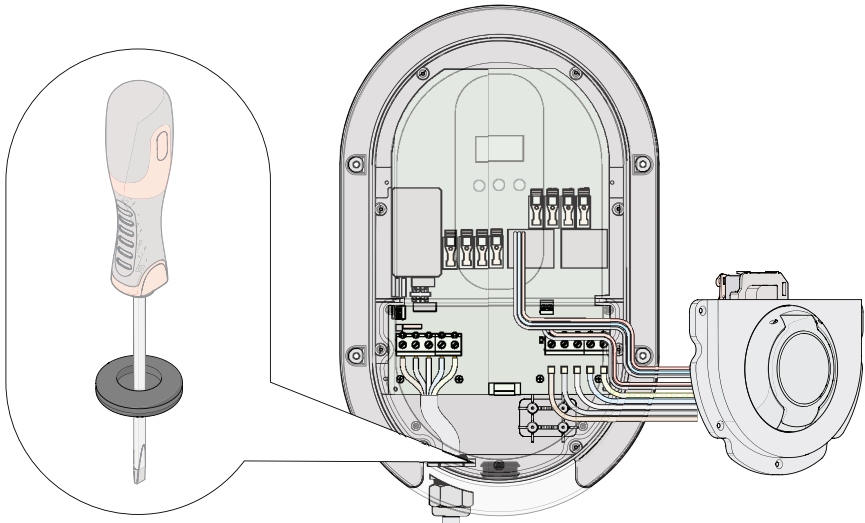

2. Punch a hole in the centre of the rubber cable grommet using a screwdriver.
3. Insert the rubber cable grommet into the centre cable inlet.
4. Guide the data cable through the rubber grommet.

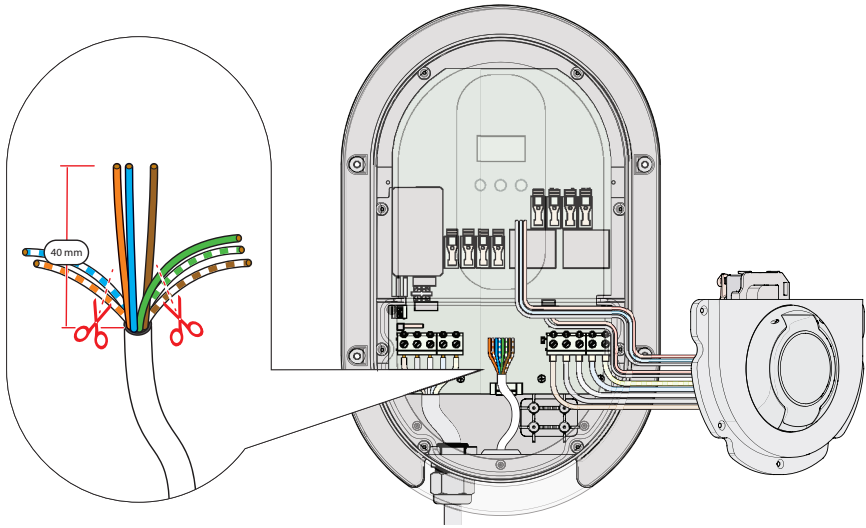

5. Strip the wires of the data cable.
6. Take the three solid coloured wires.
7. Remove the unused wires.
8. Insert the wires into the terminal block connector in the exact same order as in the main controller charger.
9. Secure the wires to the terminals. Use a voltage tester screwdriver.

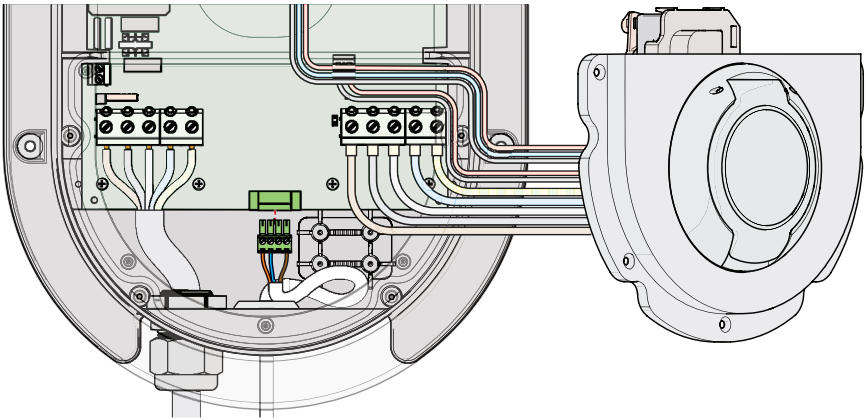

10. Insert the terminal block connector into the charger.

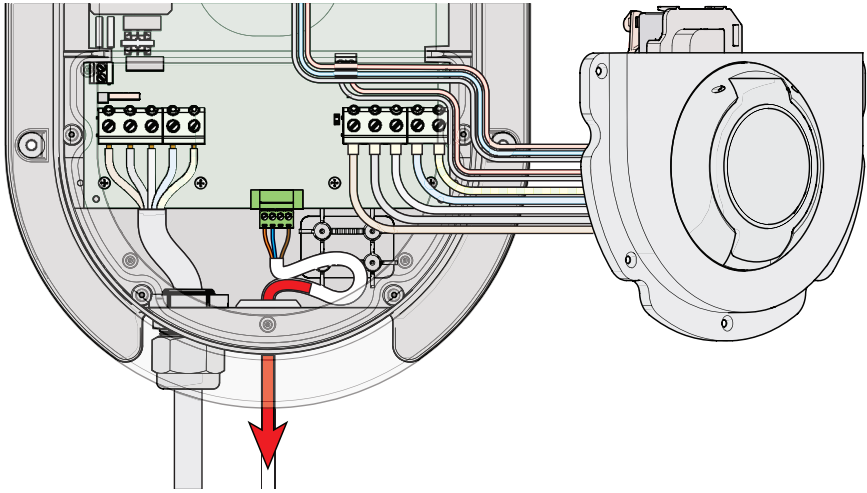

11. Gently pull the excess ethernet cable out of the charger.
12. Repeat the installation steps for Sub chargers in daisy chain configuration.

Note: Only the Main Controller is directly connected to the sensorbox.

5.8. Checks before finishing the installation

- Check if all phase, neutral and earthing wires are properly connected.
- Check if the data cables are wired correctly and the order of the coloured wires matches on both sides.
- Check if all cables are free of damage and are properly secured.
- Check if the current transformers are properly installed around the phase wires of the main power grid.
- Check if the current transformers are plugged into the correct phase inputs of the sensorbox.
- Check if the housing is correctly closed and no loose wires are visible or exposed.

5.9. Finish the installation

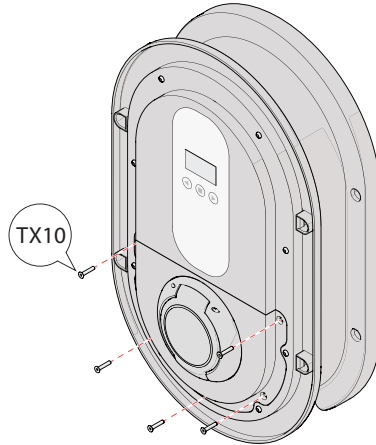

1. Secure the housing lid in place with the five Torx screws using a size TX10 screwdriver.
-

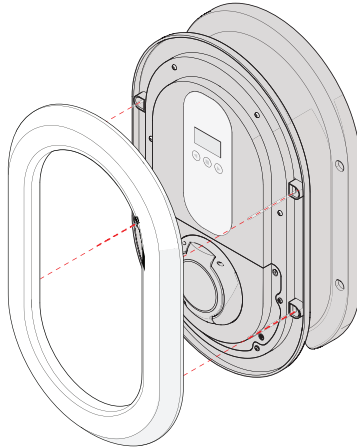

2. Click the front cover ring on the charger housing.
-

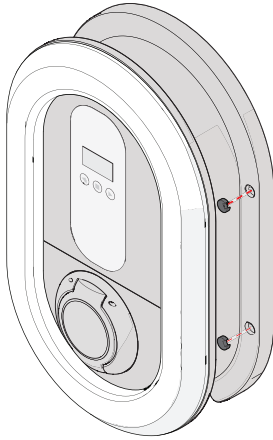

3. Place the four screw caps to cover the mounting screws.

Congratulations, you have finished installing the charger. Before the charger is ready for use, you must first commission the charger.

6. Commissioning

Switch the Main Circuit Breaker (MCB) in the consumer unit back on to provide power from the main grid to the charger(s). The charger switches on and boots up. The power LED lights up green to indicate the charger is powered.

The booting sequence is finished when the display shows the Home screen, with the active charge mode displayed at the top.

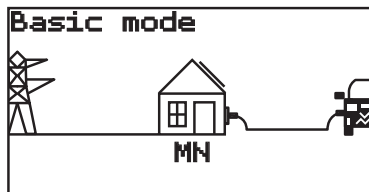





6.1. Initial configuration of the charger

NOTICE

The INSTALLER SETUP menu should only be accessed by a qualified technician. In this menu you can adjust settings that, if entered incorrectly, could damage the installation.



Before the charger is ready for use, you need to configure the initial setup parameters:

To enter the INSTALLER SETUP menu, press: , , ,  and .

A screenshot of a monochrome LCD display showing the "INSTALLER SETUP" menu. The text "INSTALLER SETUP" is at the top, and "<- CHG MODE ->" is displayed below it.

Note: After 2 minutes of inactivity, the display automatically returns to the Home screen without saving changes.

Note: It is not possible to enter the settings menu during a charging session.

Use  &  to switch between the settings and press  to enter the selected setting.

Configure the following settings for the charger.

CHG MODE Select the desired charge mode.
Available options: Basic, Smart, Smart Solar, Pure Solar.
Default: Basic.

Note: Pure Solar mode is not compatible with power sharing. If you set the charge mode to Pure Solar, power sharing will be disabled.

Note: See chapter 2 for more information on the charge modes.

POWER SHARING If you have a single charger, leave this option Disabled.
If you have multiple chargers interconnected with data cables, activate power sharing.
Set the charger that is directly connected to the sensorbox to: Main Controller
Available options: Disabled, MAIN, SUB1, SUB2, SUB3.
Default: Disabled.

Note: Make sure every sub charger is set to a unique SUB number.

Note: Make sure only one of the interconnected chargers is set to "Main Controller".

Note: Pure Solar mode is not compatible with power sharing. If you enable power sharing, the charge mode will be set to Smart Solar.

I-MIN Set the minimum required charging power of the charger.
Range: 5A - 16A.
Default: 6A.

I-MAX Set the maximum allowed charging power of the charger.
Range: 7A - 32A.
Default: 16 or 32A, depending on the charger model.

I-MAX HOME Set the maximum available power consumption of the main grid. This value is important for Load Balancing and/or dynamic charging.
Range: 10A - 99A.

Note: This option is only used in SMART and SOLAR mode, or when the power sharing option has been set to Main Controller for this charger.

I-MAX Sys Set the maximum available power consumption of the main grid. This value is important for Load Balancing and/or dynamic charging.
Range: 10A - 99A.

NUM.FASES Select the amount of phases on which the solar panel installation is installed.

Note: This value is only used when the charge mode is set to Pure Solar or Smart Solar.

Imin smSolar Set the minimum required charging power of the charger for the Smart Solar charge mode
Range: 6A – 10A.

Imin puSolar Set the minimum required charging power of the charger for the Pure Solar charge mode.
Range: 6A – 16A.

SunOnDelay Set a charging delay time after net power generation is detected (e.g. from solar panels).
Range: 1 min – 20 min.

SunOffDelay Set a delay time for the charger to stop charging after net power generation is no longer detected.
Range: 15 min – 60 min.

ERR MEMORY Check for error message history.

EXIT SETUP Save your changes and exit the SETUP menu.

6.2. Testing

It is important for the correct functioning of the charger to check if the sensorbox is connected properly.

1. Temporarily switch off the solar panel installation.
2. Check if the LED on the sensorbox periodically blinks red three times.
3. Navigate to the Actual current screen.
4. Check the values for I1, I2, and I3. The measurements should only show positive values.
5. If any of these values is negative, reverse the 3.5 mm jacks of L2 and L3, and check if the values are positive.
6. Switch the solar panel installation back on.

7. Use



7.1. Display overview

When the charger is booted up and ready for use, the Home screen is displayed. The Home screen provides a quick visual overview of the actual power grid situation, with the currently active charge mode shown in the top of the screen.

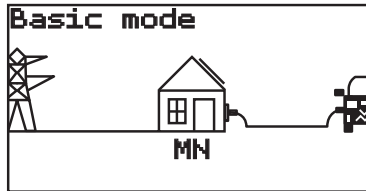
When an EV is detected, a Car icon is displayed on the right side of the screen.



- 1 Selected charge mode
 - 2 Main grid supply
 - 3 Car icon - Connected EV detected
 - 4 Power sharing role indicator
- MN = Main controller
SUB1 = sub charger no. 1
SUB2 = sub charger no. 2
SUB3 = sub charger no. 3

The display has multiple screens. Use the arrow buttons  &  to navigate through the screens.

Actual power screen

The Actual power screen shows the actual power in Watt being used to charge the EV, and the lifetime total kWh used by the charger.

```
P1: 0.0 W
P2: 0.0 W
P3: 0.0 W
Et: 803.6 kWh
```

Actual current screen

The Actual current screen shows the actual currents per phase in Amps being used to charge the EV.

```
I1: 0.0 A
I2: 0.0 A
I3: 0.0 A
Charger currents
```

Actual voltage screen

The Actual voltage screen shows the actual voltages per phase in Volts being used to charge the EV.

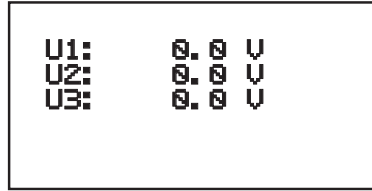

Irms sensorbox screen

The Irms sensorbox screen shows the actual currents per phase in Amps of the main grid as measured by the sensorbox.

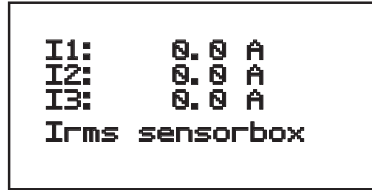

History screen

While in the Actual current, Actual power, Actual Voltage or Irms sensorbox screen, press the  button to enter the History screen.

The History screen shows the power consumption of the most recent charging sessions.

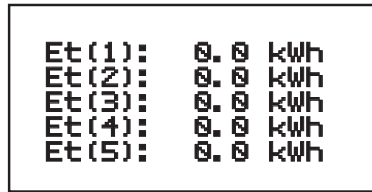

7.2. Start charging

7.2.1. Using the selected charge mode

1. Plug your charging cable into the socket of the charger.
2. Plug the other side of your charging cable into your EV.

The Car icon appears in the home screen to indicate that the EV is detected.

Any active charging delay is displayed in the right corner, above the EV:

Charge delay screen

NOSUN Insufficient power is generated by the solar panels to start a charging session.

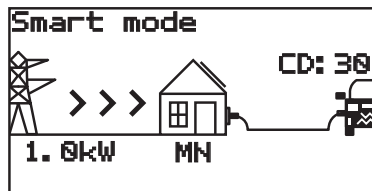

SU Sufficient power is generated by the solar panels to start a charging session. The SunOnDelay timer is activated and the remaining time before charging is displayed. When the timer runs out, the charging session will start.

SD The power generated by the solar panels has decreased to an insufficient level. The SunOffDelay timer is activated and the remaining charge time is displayed.

When the timer runs out, the charging session will stop.

CD The ChargeDelay timer is activated. The remaining time before charging is displayed.

Active charging session screen

- When the available capacity of the power grid is within the limits of the active charge mode and any set delay has expired, the charging session will automatically start.

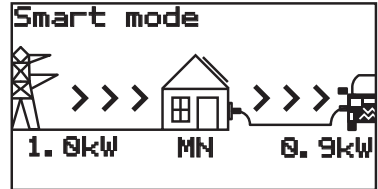

Note: The charging LED lights up blue to indicate that a charging session is in progress.

Note: The charging cable is locked during charging and cannot be removed until the charging session has ended.

7.2.2. Using the Charge now feature

If you immediately need to start a charging session, you can switch to Smart charge mode for one single charging session using the 'Charge now' feature.

Regardless of the active charge mode, e.g. smart solar, the charger immediately starts the charging session if the available capacity on the power grid is within the set limits (I-Min and I-Max).



- Press  to access the Charge now feature from the Home screen.
- Select YES using  and press  to start the charging session.

Note: After the charging session has finished, the charger returns to the active charge mode, e.g. smart solar.

7.3. During charging

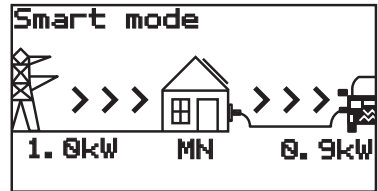
During a charging session, the direction of the current and the measured power usage is displayed in kW.



Note: In Basic Charge mode, you can adjust the I-MAX during a charging session. Press  and adjust the value using  & .

7.3.1. Charging paused

In case there is less than 6A available on the main grid, the charging session will automatically be paused.

Switch off any power demanding devices or wait until more than 6A power is available.

As soon as there is sufficient available power, the charging session will automatically resume.

CHARGING PAUSED
NO CURRENT LEFT

7.4. Stop charging

The charging session automatically stops when the EV is fully charged.

The display no longer shows current directions and power usage values.

8. Settings



To enter the USER SETUP menu, press and hold  for five seconds.



USER SETUP
← CHG MODE →

Note: It is not possible to enter the settings menu during a charging session.

Note: After 2 minutes of inactivity, the display automatically returns to the Home screen without saving any changes.

Use  &  to switch between the settings and press  to enter the selected setting.

You can configure the following settings:

CHG MODE Select the desired charge mode.
Available options: Basic, Smart, Smart Solar, Pure Solar.
Default: Basic.

Note: See chapter 2 for more information on the charge modes.

I-MIN Set the minimum required charging power of the charger.
Range: 5A - 16A.
Default: 6A.

I-MAX Set the maximum allowed charging power of the charger.
Range: 7A - 32A.
Default: 16 or 32A, depending on the charger model.

Imin smSolar Set the minimum required charging power of the charger for the Smart Solar charge mode
Range: 6A - 10A.

Imin puSolar Set the minimum required charging power of the charger for the Pure Solar charge mode.
Range: 6A - 16A.

SunOnDelay	Set a charging delay time after net power generation is detected (e.g. from solar panels). Range: 1 min – 20 min.
SunOffDelay	Set a delay time for the charger to stop charging after net power generation is no longer detected. Range: 15 min – 60 min.
ERR MEMORY	Check for error message history.
EXIT SETUP	Save your changes and exit the SETUP menu.

9. Troubleshooting

The charger is equipped with monitoring software that detects faults and displays them as error messages in the display. Every fault has a specific error code for easy identification. An overview of the error codes is shown below.

Error code	Fault	Possible solution
100	CP error, faulty values or short circuited. Possible causes: Damaged charging cable Dirty connectors Issue originating from the EV.	Switch off the power to the main grid. Clean the connector(s) of the charging cable. Check the cable for any visible damage. Switch the power to the main grid back on. Try charging with a different charge cable. Try charging a different EV. Try charging the EV with a different charger. If the error persists: Please contact Ratio Electric or a qualified electrician to have the cable inspected/ replaced.
101	Grounding fault Possible causes: Damaged charging cable Damaged charger	Switch off the power to the main grid. Switch the power to the main grid back on. Press and hold  for 10 seconds to power cycle the charger. If the error persists, Please contact Ratio Electric or a qualified electrician to have the charger inspected.

102/112	Maximum temperature exceeded while charging. Possible cause: long, high current charging sessions in high ambient temperatures.	Allow the charger to cool down before resuming the charging session. When the charger has cooled down, the error code disappears and the charger returns to regular operation.
111	No communication between the charger and the sensorbox.	Check if the connectors are properly inserted in the sensorbox and charger. Check if the sensorbox is powered. Check the data cable for visible damages. Replace the data cable if necessary.

If there is no error code:

- Check the charger, charge cable and connector for any visible damage.
- Make sure the power LED on the charger is on.
- Make sure that the charge cable is properly inserted and locked into your EV.

If you cannot find the reason why your charger is not working properly, please contact your local reseller or Ratio Electric B.V.

10. Maintenance

Ratio Electric chargers are practically maintenance-free, aside from periodic cleaning of the housing.

1. Switch off the charger before cleaning the housing.
2. Clean the Solar Box using a soft cloth lightly moistened with mild detergent solution.

⚠ WARNING

Risk of electric shock

- Switch off the charger before cleaning the housing.
- Be careful when cleaning the inlets and socket, do not use excessive amounts of water to avoid water leaking into the charger.

NOTICE

Risk of damage to the product

- Do not use aggressive chemicals to clean the charger.
- Do not use coarse cleaning tools that may damage or scratch the surface of the charger.
- Never use any type of abrasive pad, scouring powder, or flammable solvents such as alcohol or benzene.

11. Service

To avoid risk of electric shock, only qualified electricians should perform service or maintenance on the charger. If your charger is in need of servicing, please contact Ratio Electric, your local vendor or a qualified electrician.

12. Warranty

Ratio Electric B.V. warrants this product to be free from defects in material, manufacture and design for a period of 3 years after the date of purchase. If this product is defective in materials, manufacture or design during this warranty period, Ratio Electric B.V. will, at its option, repair or replace the product.

Repair parts and/or replacement products may be either new or reconditioned at Ratio Electric B.V. discretion.

This limited Carry-In Warranty does not include service to repair damage from improper installation, improper connections with peripherals, external electrical fault, accident, disaster, misuse, vandalism, unauthorized alteration or repair, abuse or modifications to the product not approved in writing by Ratio Electric B.V.

Any evidence of an attempt to disassemble the Solar Box will void this warranty.

Any service repair outside the scope of this limited warranty shall be at applicable rates and terms then in effect.

13. Disposal

If the charger is defective beyond repair, or you no longer wish to use the charger, please recycle the charger according to local applicable rules and guidelines regarding the disposal of electrical devices.

Appendix 1. FCC compliance

This device complies with Part 15 of the FCC rules. Operation is subject to the following two conditions:

- This device may not cause harmful interference.
- This device must accept any interference received, including interference that may cause undesired operation.

This product has been designed to protect against Ratio Frequency Interference (RFI). However, there are some instances where high powered radio signals or nearby RF-producing equipment (such as digital phones, RF communications equipment, etc.) could affect operation.

If interference to your charge station is suspected, we suggest the following steps be taken before consulting your Service Representative for assistance:

1. Reorient or relocate nearby electrical appliances or equipment during charging.
2. Turn off nearby electrical appliances or equipment during charging.

CAUTION

Changes or modifications to this product by other than an authorized service facility may void FCC compliance.

Ratio ELECTRIC



For more information see the
extended manual online.

Ratio Electric B.V.

Ambachtsstraat 12
NL – 3861 RH Nijkerk
The Netherlands
Tel. +31-33-2452360
info@ratio.nl
www.ratio-electric.com